



ASSEMBLY INSTRUCTIONS

GSRN20 & GSRN30

1 Mark drilling points

2 people are required for assembly.

Person 1 holds the cloakroom rail at the point where the cloakroom rail is to be mounted.
The wall bearings are already pre-assembled.

1.1



1.2

Person 2 marks the assemblage points on the left and on the right.
To do this, use a pen whose lines can be removed afterwards with as little effort as possible;
e.g. a pencil with a light lead.

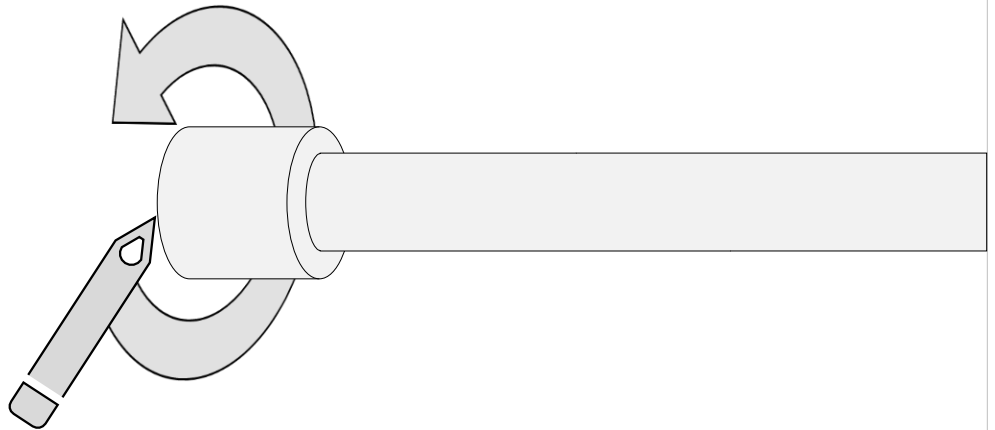

Carefully put the cloakroom rail back down.

Find the center of the two drawn circles. After that, remove the two circles, leaving only the center marks.

1.3

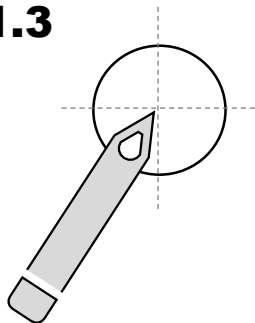

1.4

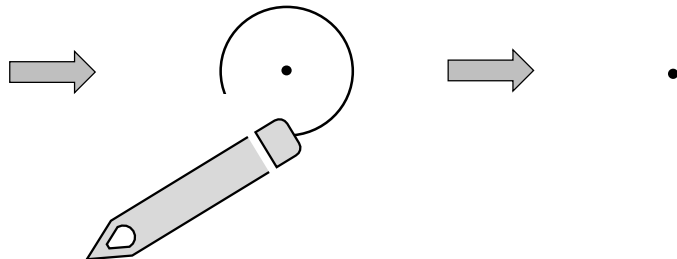

2 Drill holes

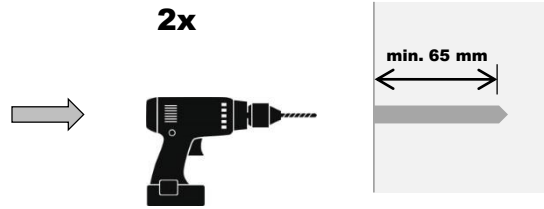

3 Insert dowels

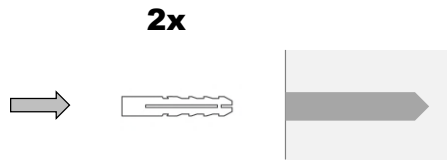

4 Dismantle the wall brackets from the cloakroom rod on both sides

4.1

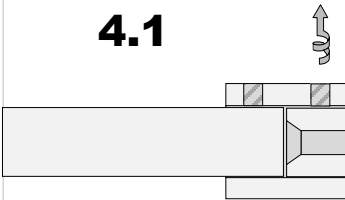

4.2

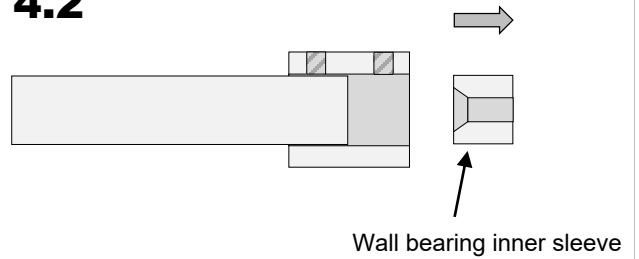

Please loosen the fixing screws only slightly.
Please do not turn this off.

4.3

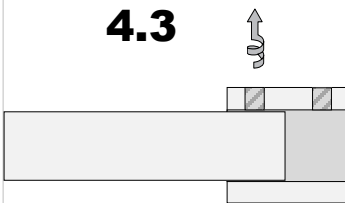

4.4

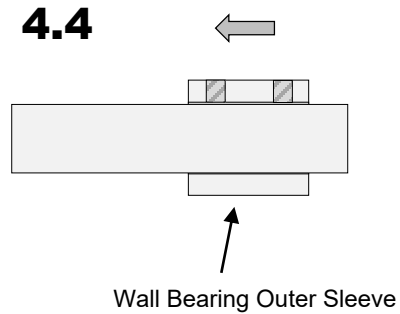

5 Installation of the wall bearing inner sleeves

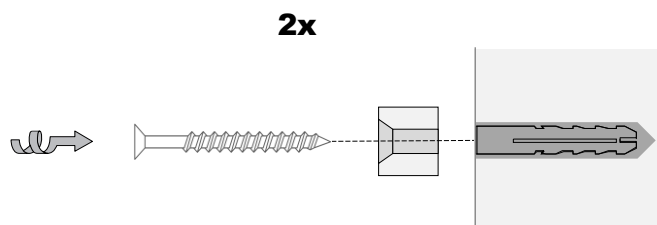

6 Assembly of the wardrobe rod

Person 1 holds the cloakroom rail between the two screwed wall bearing inner sleeves.

6.1



Person 2 pushes the wall bearing outer sleeves outwards - all the way to the wall. TIP: If you turn the outer sleeves so that the fixing screws point backwards, they will no longer be visible from the front later.

6.2



Person 2 tightens all 4 fixing screws with the Allen key provided. Then the assembly is complete.

6.3

